

L200



INTELLIGENT MOTION



2015

GENERATIONS OF INTELLIGENT MOTION

To those in the know, Mitsubishi has long been known as the clever car company: a pioneer who is quietly responsible for automotive innovations ranging from the four-wheel drive technology which effectively sired one of the world's favourite classes, to the world's first SUV plug-in hybrid electric vehicle.

The 1970s were epitomized by fringing and flares, Concorde, Watergate, Charlie's Angels and Saturday Night Fever, and by the very first compact Mitsubishi pick-up. This two-door, two-wheel drive truck immediately scooped "Pick-up of the Year" in the States but, due to import quotas, it would be years before it made its UK debut.

In 1987 the rugged and reliable L200 Series 2 was launched, setting a precedent with a level of warranty never before seen in a commercial market and earning a dedicated following amongst press and public alike; but it was the introduction of the Series 3 which really set the UK market alight. Stateside the double cab pick-up had already become a firm favourite, but this particular pick-up introduced real style and comfort into the mix, and so was equally at home in mid Wales as in the Mid West. Offering four doors, five seats, virile looks and an off-road capability to rival that of the legendary Shogun in what had previously been considered to be purely a working vehicle, this L200 changed both British perception and the market.

2006 saw a revolution. Whilst the higher specified variants of the third series L200 had established the concept of combining work and play, the cutting edge design of the Series 4 positioned the L200 as a true, crossover breed, sport-utility truck. Offering excellent performance, exceptional manoeuvrability, superior space and safety, and arguably the best 4WD system of any pick-up ever, over the years it has been awarded every major accolade and remains consistently in demand. But, whilst still available in single, club and double cab guises*, 2015 sees the beginning of a new era: the L200 double cab Series 5. Smoother, quieter, roomier; more sophisticated, more comfortable and even more aerodynamic: from the genes of a class leader emerges another – the all new, class leading, Mitsubishi L200 double cab.

*This brochure describes the new L200 Series 5; for information on the ongoing Series 4 range please refer to page 18 onwards.



1982-1986

1986-1996

1996-2006

2006-2015



EVOLUTIONARY BODY; REVOLUTIONARY DRIVE

At first glance, this fifth generation L200 double cab appears more evolution than revolution but, whilst its DNA is undeniable, in reality it's all new. It's sleek and muscular enough to reap plenty of street cred and the way it drives will have as much impact on the pick-up market as did the launch of the iconic fourth generation model almost ten years ago. It has a new engine, new suspension, new steering and new transmission, both manual and automatic, and that's just the start.

Of course, the sleek shape of the new L200 isn't designed simply to be easy on the eye, it's designed to make it the most aerodynamically efficient double cab you can buy. This aerodynamic excellence combines with a new 2.4 litre diesel MIVEC engine to return both exceptional performance and outstanding fuel economy – as much as 27% better than any other pick-up you can buy. Uncannily quiet, even with the

windows down, the engine is smooth and refined and incredibly responsive, and its exceptional torque characteristics are superbly matched by a new six-speed manual transmission with a light, smooth shift action, or, on Warrior and Barbarian derivatives, the option of a five-speed automatic with Sports Mode manual facility and paddle shift.

Add to the mix a revised suspension set up which ensures that the L200 rides more like an SUV than an LCV, feeling composed and settled around bends and over potholes. This is a highlight which is matched by the steering: light at low speeds, and with considerably reduced lock-to-lock revolutions, it emphasises the L200's extreme manoeuvrability, and with a turning circle of just 11.8m that's the best in class by far; better even than that of some small cars. Some day all trucks will drive this way.

POWERING THE PICK-UP

The L200 is the very first pick-up with an all-aluminium engine, dramatically reducing weight which in turn aids fuel economy and improves dynamic performance. On the L200 4Life, Auto Stop & Go further aids both fuel consumption and emissions, and the highly responsive compact turbocharger endows Titan, Warrior and Barbarian models with an impressive 178 bhp output. This enables you to power up to 62mph in just 10.4 seconds, maintain that speed at barely 2000rpm, and still have plenty of torque to call on when you need it. In short, the L200 is the very best pick-up you can buy for performance, emissions and fuel economy; in fact, it's a win, win situation.





UK RHD specification differs slightly from that shown – see pages 24/25 for full details.

PICK OF THE PICK-UPS INSIDE

You might choose this pick-up for its ride alone; but then again, you might pick it for its class. A perfect balance between practical, durable materials and 'car-like' refinement, its list of standard specifications reads more like that of a top-end saloon: central locking with keyless entry, tactile leather on steering wheel and gearshift knob, complementing leather seats in the Warrior and Barbarian models, electric windows to both front and rear, electric heated* door mirrors for optimum vision under all conditions, and air conditioning of course – climate control with dual zone facilities providing separate settings for driver and front passenger*. It even includes cruise control, a Bluetooth® hands free 'phone connection, and good sound systems with steering wheel remote control as standard, as well as a touch screen satellite navigation system on the Warrior and Barbarian.

*Not 4Life

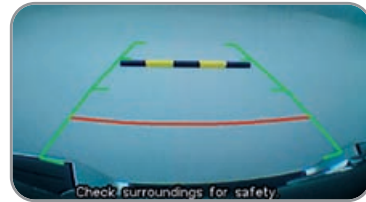

REVERSING CAMERA

Excellent all-round visibility is further enhanced by a reversing camera, standard on both Warrior and Barbarian models



HANDS FREE FOR SAFETY

Phone, audio and paddle shifters for the automatic Sports Mode provide control without releasing the steering wheel.



5-SPEED AUTOMATIC TRANSMISSION WITH SPORTS MODE



6-SPEED MANUAL TRANSMISSION



UK RHD specification differs slightly from that shown – see pages 24/25 for full details.

NOW YOU'RE SITTING COMFORTABLY

Maximising space has always been a Mitsubishi strong point and, despite its relatively compact size, the last L200's cabin provided better legroom than any other cab in the class; well, this one is even bigger. The seats are even better too; much, much better. Drivers will find their position very car-like, sitting down snugly in the seats instead of the traditional pick-up perch. Rear seat passengers are cosseted with a 25° reclined seat-back and good headroom, making this their pick of the pick-ups too, and everyone benefits from the excellent sound insulation: combined with the naturally quiet engine, this latest L200 cruises more than 2dB more quietly than its peers.

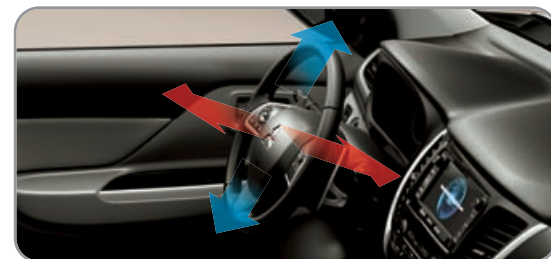

The L200 is one of only two pick-ups with height and reach adjustment for the steering wheel.

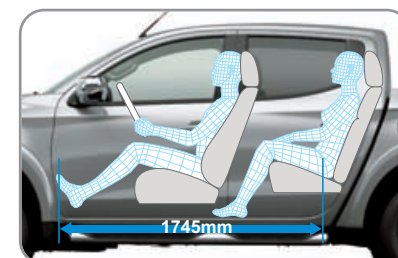

CLASS-LEADING CABIN LENGTH

An additional 20mm of legroom makes the L200's long-term longest cab in the class even more generous.

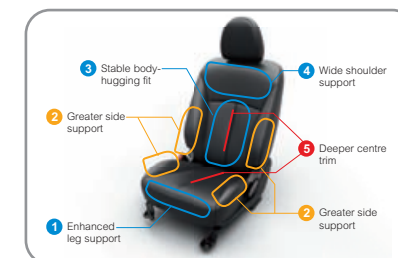

LUXURIOUS NEW FRONT SEATS

Wider front seats, ergonomically designed with deep cushions and large side bolsters, are heated in some models.



This L200 double cab offers greater stowage capacity due to its deeper cargo side walls.

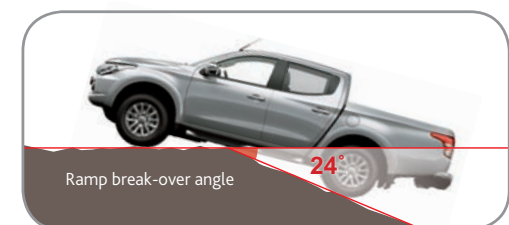

The L200 is spider-like over the steepest terrain, climbing seemingly impossible angles with ease. Despite boasting one of the best approach angles in its class, the pick-up has an extended front overhang which prevents water from splashing up and impairing visibility, even when traversing water at relatively high speeds.

TAMING THE ROUGH AND THE SMOOTH

The L200 has long been acknowledged to be the prince of pick-ups off-road, and this latest incarnation is even more competent. With its smooth torque delivery, winding up to an impressive 317 lb.ft. at just 2500rpm*, that quiet, economical engine, so impressive on-road, is equally suited to tougher work. It powers through mud, slush, snow and sand as effectively as it attacks the asphalt, whilst the new suspension set up skilfully irons out deeper bumps. Traction is never in question: the Super Select drivetrain is borrowed from the iconic Shogun and has proven itself supreme over some of the world's most inhospitable terrain, whilst the Easy Select system in operation on 4Life models also features a heavy-duty rear differential lock to provide extra traction for when the

going goes beyond tough! Where others fear to tread is a stroll in the park for this pick-up. Titan, Warrior and Barbarian models remain unique, being the only pick-ups on the market to enable on-road driving in the dry with either two- or four-wheels engaged. This provides the option of extra grip when you need it, when towing for example. Indeed, the L200 is something of a towing supremo. With a braked capacity of 3100kg and a total load capacity (the maximum total weight which can be carried in the load bed whilst towing) of 4090kg, it's the brawniest packhorse in the bunch.

*280 lb.ft at 1500-2500rpm on 4Life



2H
For normal road conditions



4H
For rough roads and hazardous conditions



4HLc
For rugged terrain with low-grip surfaces



4LLc
For steep hills, mud, sand, deep snow, etc

SUPER SELECT

L200s with Super Select allow you to shift from 2WD (2H) to 4WD (4H) on the move at speeds of up to 62mph using the drive mode selector. In 4HLc the centre differential is locked and power distributed evenly between the front and rear wheels, whilst engaging 4LLc lowers the centre differential gear ratio. When shifting in or out of 4LLc the vehicle must be stationary. With the Easy Select drivetrain, the vehicle may also be shifted from 2WD to 4WD on-the-fly.

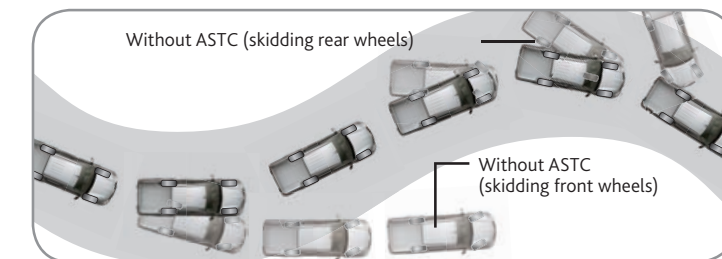

During cornering, Active Stability & Traction Control independently regulates the braking force to the wheels to help maintain stability. It also optimises traction whenever wheel spin is detected by controlling the engine output and applying brake force to the spinning wheels.

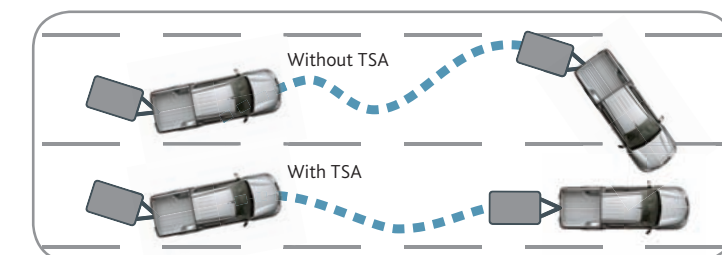

A real boon when towing, TSA increases stability. If vehicle swaying is detected, it automatically controls the engine power and the braking force at each wheel to stabilise the vehicle and trailer.

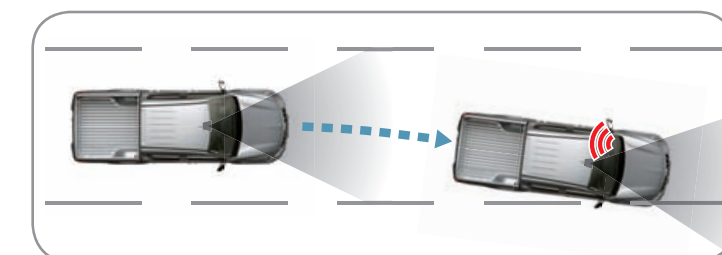

The LDW system detects potential lane drift via a windshield camera and alerts you with an audible alarm and warning light. It only operates at speeds in excess of 40mph.

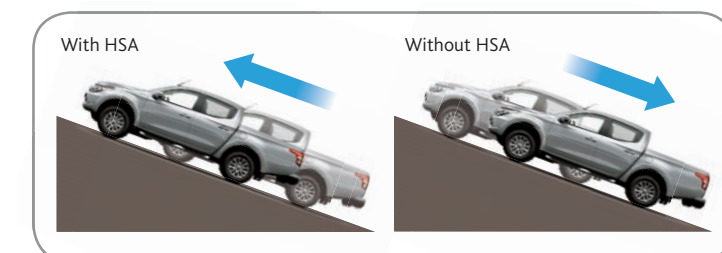

On steep hills HSA helps prevent you from rolling backwards by maintaining the braking force for up to two seconds after the brake is released and before the accelerator is applied.

SETTING A PRECEDENT FOR SAFETY

The L200 was the very first pick-up to feature a traction control system. This active safety feature works alongside technical innovations like ABS with EBD (which adjusts the level of braking power applied between the front and rear wheels, depending upon the load), Brake Assist (power assistance for the pedal under emergency braking), an Emergency Stop signal System which automatically alerts other drivers to a hazardous situation, and Trailer Stability Assist for safer towing. Features like the Lane Departure Warning system, Hill Start Assist and the Bi-Xenon headlamps which turn night into day, also make the L200 both safer and easier to drive. But, should the worst happen and you come closer than is desirable to another solid object, you'll find the L200's ultra-tough body and multiple airbags a safe place to be.

Specifications vary by model – please refer to pages 24/25 for full details.



THE IMPORTANCE OF RISE

Mitsubishi's RISE (Reinforced Impact Safety Evolution) system ensures a structure which absorbs energy and maintains the integrity of the cabin in the event of a collision.

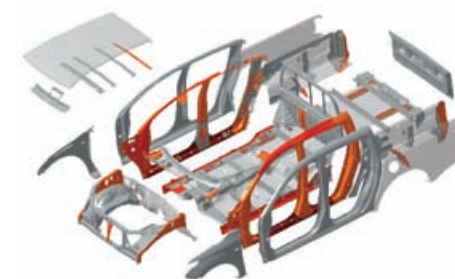

LIGHTWEIGHT YET RIGID

High tensile steel provides strength without weight, supported by enhanced rigidity around structures like the engine housing, under the cargo bed and the chassis frame.



SEVEN SRS AIRBAGS

Front, front side, curtain and a driver's knee airbag protect occupants in the event of a collision.



A WINNING FORMULA

Before this brochure even went to press, the L200 had already been voted 'Best Pick-up' by Auto Express. They were impressed by its driving dynamics, running costs and 'car-like sophistication'. Maybe they noticed the little touches like privacy glass and rain and dusk sensors* – the attention to detail which makes the L200 such an easy vehicle to live with. And remember, for company vehicle owners and drivers it still enjoys all the considerable tax advantages of an LCV, even if you fit a canopy.



*Not 4Life

me & my MITSUBISHI

When you buy a new Mitsubishi, you not only get a safe and reliable vehicle that is a real pleasure to drive, you also become part of the Mitsubishi family. And as our nearest and dearest, we want you to feel protected should you ever encounter a problem – that's why we have **me&my**.

All new L200s are provided with a comprehensive five-year, 62,500-mile warranty. Please ask your Authorised Mitsubishi Dealer for full details.

With the **Mitsubishi Assistance Package (MAP)** we go the extra mile. Our assistance programme is there to help should you breakdown at the roadside or at home. It provides vehicle recovery following a breakdown or accident and help if your vehicle is stolen or vandalised

and, if you should accidentally fill up with the wrong fuel, don't worry – we'll be there for you then too. What's more, you're covered 24/7 in over 30 countries throughout Europe. So whether you're on the daily school run or cruising through the Alps on your holidays, it's comforting to know that if the unexpected does happen, help is always at hand.

And should you be unlucky enough to have an accident we have **Mitsubishi First** – our customer support service for all Mitsubishi drivers following an accident. No matter which insurer you use, Mitsubishi First smooths your progress through an insurance claim, handling everything on your behalf – no hassle, no claim forms, no running about, and absolutely no cost to you.

AND ONCE YOU'RE PART OF THE FAMILY...

SERVICE WITH A SMILE

A **Mitsubishi Service Plan**, purchased at the same time as your L200, covers the first three scheduled services for a modest sum. It can be included in your vehicle's finance and transferred to a new owner when you sell.

Mitsubishi Motors also offer superior **insurance cover** at a competitive price which is specifically designed for Mitsubishi vehicles and uses only genuine parts and approved repair centres.

ACCESSORIES

A wide range of accessories is available to help fine-tune the L200 into the exact load-lugger you need, all of which enjoy a 3-year warranty if fitted at the time of purchase. A small selection is illustrated here, for details of the complete range visit www.mitsubishi-cars.co.uk/L200 or ask your dealer for the L200 accessories brochure.



- 1. Bonnet guard
- 2. Side window deflectors (set of 4)
- 3. 17" alloy wheel (for Titan, Warrior and Barbarian)
- 4. Load Liner, under-rail (over-rail also available)
- 5. Textile mats (set of 4, choice of 2 grades)
- 6. Fullbox
- 7. Rubber mats (set of 4)
- 8. GST Plus Hard Top (shown with optional roof rails)
- 9. Adventurer III Hard Top
- 10. Tonneau cover, gas lift

The vehicle exterior colour shown for items 4, 6 and 10 is not available in the UK.



L200 Series 4 Single Cab 4Life

KEY FEATURES:

- Easy Select 4WD system with rear differential lock • Mitsubishi Active Stability and Traction Control • Manual transmission • ABS with EBD • Dual SRS airbags
- Rear fog lamp • Central door locking with remote keyless entry • Electric windows
- Air conditioning • Bluetooth® hands-free telephone connection • Stereo radio/CD/MP3 player
- USB/AUX port • Ladder rack



L200 Series 4 Double Cab 4Life

KEY FEATURES

- Easy Select 4WD system with rear differential lock • Mitsubishi Active Stability and Traction Control • Manual transmission • ABS with EBD • Dual SRS airbags • Rear fog lamp
- Bluetooth® hands-free telephone connection • Stereo radio/CD/MP3 player with 4 speakers
- USB/AUX port • Colour-keyed front bumper • Black and chrome front grille • Central door locking with remote keyless entry • Electric windows • Air conditioning • Side steps



L200 Series 4 Club Cab 4Life

KEY FEATURES:

- Easy Select 4WD system with rear differential lock • Mitsubishi Active Stability and Traction Control • Manual transmission • ABS with EBD • Dual SRS airbags
- Rear fog lamp • Central door locking with remote keyless entry • Electric windows
- Air conditioning • Side steps • Bluetooth® hands-free telephone connection
- Stereo radio/CD/MP3 player • USB/AUX port • Colour-keyed front bumper
- Black and chrome front grille



L200 Series 4 Double Cab Challenger

KEY FEATURES

- 3,000kg towing capacity • Super Select 4WD system • Mitsubishi Active Stability and Traction Control • Manual transmission • 175 bhp engine • ABS with EBD • Dual SRS airbags
- Front and rear fog lamps • Colour-keyed front bumper • 17" alloy wheels with colour keyed wheelarch extensions • Tubular side steps • Chrome door mirrors and handles • Black and chrome front grille
- Central door locking with remote keyless entry • Electric windows including rear screen • Climate controlled air conditioning • Cruise control • Privacy glass
- Bluetooth® hands-free telephone connection • Stereo radio/CD/MP3 player with 6 speakers
- Electric door mirrors



NEW L200 Series 5 Double Cab 4Life

KEY FEATURES

- Easy Select 4WD system with rear differential lock • 6-speed manual transmission • Front, side, curtain and driver's knee SRS airbags • Mitsubishi Active Stability and Traction Control • ABS with EBD • Hill Start Assist • Trailer Stability Assist • Auto Stop & Go • Heavy duty suspension • Daytime running lights • 16" alloy wheels • Side steps • Central door locking with remote keyless entry • Black front grille, door mirrors and handles • Leather steering wheel and gearshift knob • Electric door mirrors • Electric windows • Air conditioning • Cruise control with adjustable speed limiter • Exterior temperature display • Stereo radio/CD player with 4 speakers • Steering wheel remote audio control • Bluetooth® hands-free telephone connection with music streaming • USB socket



UK RHD specification differs from that shown – see pages 24/25 for full details.



NEW L200 Series 5 Double Cab Warrior

KEY FEATURES

- Super Select 4WD system • 6-speed manual transmission • 5-speed automatic transmission with paddle shift • Front, side, curtain and driver's knee SRS airbags • Mitsubishi Active Stability and Traction Control • ABS with EBD • Hill Start Assist • Trailer Stability Assist • Lane Departure Warning • Reversing camera • LED daytime running lights • 17" alloy wheels • Privacy glass • Side steps • Rear bumper step • HID bi-xenon headlamps with washers • Front fog lamps • Rain and dusk sensors • Keyless operation system with engine start/stop button • Chrome front grille, door mirrors and handles • Leather seat trim with heated front seats and power driver's seat • Leather steering wheel and gearshift knob • Electric folding heated door mirrors with side indicators • Electric windows • Dual zone climate control air conditioning • Cruise control with adjustable speed limiter • Exterior temperature display • SD card satellite navigation/DAB radio with HD 7" touch-screen • Steering wheel remote audio control • Bluetooth® hands-free telephone connection with music streaming • USB socket



UK RHD specification differs slightly from that shown – see pages 24/25 for full details.



NEW L200 Series 5 Double Cab Titan

KEY FEATURES

- Super Select 4WD system • 6-speed manual transmission • Front, side, curtain and driver's knee SRS airbags • Mitsubishi Active Stability and Traction Control • ABS with EBD • Hill Start Assist • Trailer Stability Assist • Lane Departure Warning • Daytime running lights • 17" alloy wheels • Privacy glass • Side steps • Front fog lamps • Rain and dusk sensors • Keyless operation system with engine start/stop button • Chrome front grille, door mirrors and handles • Leather steering wheel and gearshift knob • Electric folding heated door mirrors • Electric windows • Dual zone climate control air conditioning • Cruise control with adjustable speed limiter • Exterior temperature display • Display audio DAB radio/CD player with 6 speakers • Steering wheel remote audio control • Bluetooth® hands-free telephone connection with music streaming • USB socket



UK RHD specification differs slightly from that shown – see pages 24/25 for full details.



NEW L200 Series 5 Double Cab Barbarian

KEY FEATURES

- Super Select 4WD system • 6-speed manual transmission • 5-speed automatic transmission with paddle shift • Front, side, curtain and driver's knee SRS airbags • Mitsubishi Active Stability and Traction Control • ABS with EBD • Hill Start Assist • Trailer Stability Assist • Lane Departure Warning • Reversing camera • LED daytime running lights • 17" alloy wheels • Privacy glass • Side steps • Rear bumper step • Soft opening tailgate • Exterior enhancement pack (mesh front grille, door handle recesses/fuel filler/tail lamp/tailgate handle bright trim) • HID bi-xenon headlamps with washers • Front fog lamps • Rain and dusk sensors • Keyless operation system with engine start/stop button • Chrome front grille, door mirrors and handles • Premium leather seat trim with heated front seats and power driver's seat • Illuminated door entry guards • Blue LED footwell lighting and puddle lamps • Leather steering wheel and gearshift knob • Electric folding heated door mirrors with side indicators • Electric windows • Dual zone climate control air conditioning • Cruise control with adjustable speed limiter • SD card satellite navigation/DAB radio system with HD 7" touch-screen • Steering wheel remote audio control • Bluetooth® hands-free telephone connection with music streaming • USB socket



UK RHD specification differs slightly from that shown – see pages 24/25 for full details.



TECHNICAL SPECIFICATIONS

Model	L200 Series 4				NEW L200 Series 5			
	L200 Single Cab 4Life Manual	L200 Club Cab 4Life Manual	L200 Double Cab 4Life Manual	L200 Double Cab Challenger Manual	L200 Double Cab 4Life Manual	L200 Double Cab Titan Manual	L200 Double Cab Warrior Manual/Automatic	L200 Double Cab Barbarian Manual/Automatic
Engine	In-line 4-cylinder 16-valve DOHC diesel engine, turbocharger with intercooler				In-line 4-cylinder 16-valve DOHC diesel engine, turbocharger with intercooler			
Engine type	In-line 4-cylinder 16-valve DOHC diesel engine, turbocharger with intercooler				In-line 4-cylinder 16-valve DOHC diesel engine, turbocharger with intercooler			
Auto Stop & Go (AS&G)	-				-			
Fuel system	Diesel, electronic common-rail direct injection				Diesel, electronic common-rail direct injection			
Emissions control system	Oxidation catalytic converter with closed flow Diesel Particulate Filter		Oxidation catalytic converter with closed flow Diesel Particulate Filter		Oxidation catalytic converter with closed flow Diesel Particulate Filter		Oxidation catalytic converter with closed flow Diesel Particulate Filter	
Displacement	2477		2477		2442		2442	
Bore/stroke	91.1 x 95.0		91.1 x 95.0		86.0 x 105.1		86.0 x 105.1	
Compression ratio	16.5		16.5		15.5		15.5	
Maximum output	100 (134) / 4000		100 (134) / 4000		113 (175) / 3750		133 (178) / 3500	
Maximum torque	314 (231) / 1500 – 2680		314 (231) / 1500 – 2680		400 (295) / 2000 – 2850		430 (317) / 2500	
Performance/Fuel Consumption/Emissions								
Maximum speed	103 (167)		103 (167)		111 (179)		111 (179) [110 (177)]	
Acceleration 0-62 mph	15.2		15.0		12.1		10.4 [11.8]	
lts/100km (mpg)	Urban mode		9.1 (31.0)		9.2 (30.7)		8.1 (34.9) [8.4 (33.6)]	
	Extra urban mode		7.0 (40.4)		7.2 (39.2)		5.7 (49.6) [6.5 (43.5)]	
	Combined		7.7 (36.7)		7.9 (35.8)		6.6 (42.8) [7.2 (39.2)]	
CO ₂ emissions	199		204		208		173 [189]	
Emissions compliance	EU-5b		EU-5b		EU-5b		EU-5b	
Suspension/Steering								
Front axle	Independent, double wishbone with coil springs		Independent, double wishbone with coil springs		Independent, double wishbone with coil springs		Independent, double wishbone with coil springs	
Rear axle	Rigid, elliptic leaf springs		Rigid, elliptic leaf springs		Rigid, elliptic leaf springs		Rigid, elliptic leaf springs	
Brakes	Anti-lock Braking System with Electronic Brakeforce Distribution (ABS with EBD)							
	Front	294mm (11.6") ventilated discs	294mm (11.6") ventilated discs	294mm (11.6") ventilated discs	294mm (11.6") ventilated discs	294mm (11.6") ventilated discs	294mm (11.6") ventilated discs	294mm (11.6") ventilated discs
	Rear	295mm (11.6") drums	295mm (11.6") drums	295mm (11.6") drums	295mm (11.6") drums	295mm (11.6") drums	295mm (11.6") drums	295mm (11.6") drums
Steering	Rack and pinion, power-assisted		Rack and pinion, power-assisted		Rack and pinion, power-assisted		Rack and pinion, power-assisted	
Min. turning circle	11.8 (38.7)		11.8 (38.7)		11.8 (38.7)		11.8 (38.7)	
Tyres	205/80R16 108R		205/80R16 104S		245/65R17 111S		245/65R17 111S	
Wheels	16" X 6J Steel		16" X 6J Steel		17" X 7J Alloy		17" X 7.5J Alloy	
Driveline/Transmission	Easy Select 4WD with Mitsubishi Active Stability & Traction Control and Brake Assist				Super Select 4WD with Mitsubishi Active Stability & Traction Control and Brake Assist		Super Select 4WD with Mitsubishi Active Stability & Traction Control and Brake Assist	
Type	Easy Select 4WD with Mitsubishi Active Stability & Traction Control and Brake Assist				Super Select 4WD with Mitsubishi Active Stability & Traction Control and Brake Assist		Super Select 4WD with Mitsubishi Active Stability & Traction Control and Brake Assist	
Rear differential lock	STD		STD		STD		-	
Clutch	Manual	Hydraulic	Hydraulic	Hydraulic	Hydraulic	Hydraulic	Hydraulic	Hydraulic
	Automatic	-	-	-	-	-	Torque converter	Torque converter
Transmission	Manual	5-speed	5-speed	5-speed	5-speed	6-speed	6-speed	6-speed
	Automatic	-	-	-	-	-	5-speed INVECS-II with Sports Mode manual shift facility and paddle shift	
Gear ratios	1st	4.313	4.313	4.313	4.313	4.280	4.280 [3.520]	4.280 [3.520]
	2nd	2.330	2.330	2.330	2.330	2.298	2.298 [2.042]	2.298 [2.042]
	3rd	1.436	1.436	1.436	1.436	1.437	1.437 [1.400]	1.437 [1.400]
	4th	1.000	1.000	1.000	1.000	1.000	1.000 [1.000]	1.000 [1.000]
	5th	0.788	0.788	0.788	0.788	0.776	0.776 [0.716]	0.776 [0.716]
	6th	-	-	-	-	0.651	0.651 [-]	0.651 [-]
	Reverse	4.220	4.220	4.220	4.220	3.959	3.959 [3.224]	3.959 [3.224]
Transfer gear ratio	High / Low	1.000 / 1.900	1.000 / 1.900	1.000 / 1.900	1.000 / 1.900	1.000 / 2.566	1.000 / 2.566	1.000 / 2.566
Final gear ratio		3.917	3.917	3.917	3.917	3.692	3.692 [3.917]	3.692 [3.917]
Dimensions								
Exterior l x w x h	5040 x 1750 x 1775		5120 x 1750 x 1775		5185 x 1750 x 1775		5185 x 1815 x 1780	
Loadbed								
Length x width x height	2220 x 1470 x 405		1805 x 1470 x 460		1505 x 1470 x 460		1470 x 1470 x 475	
Width between wheelarches	1085		1085		1085		1085	
Cargo floor height	845		855		845		850	
Ground clearance (unladen)	200		200		205		205	
Track Front / Rear	1505 / 1500		1505 / 1500		1520 / 1515		1520 / 1515	
Wheelbase	3000		3000		3000		3000	
Approach angle	32.7		32.7		33.4		30.0	
Departure angle	27.2		24.4		23.8		25.0	
Ramp breakover	26.3		24.4		24.7		23.0	
Weights/Volumes								
Seating capacity	2		4		5		5	
Fuel tank capacity	75 (16.5)		75 (16.5)		75 (16.5)		75 (16.5)	
Gross vehicle weight	2890 (6372)		2850 (6284)		2900 (6393)		2905 (6404) [2910 (6415)]	
Kerb weight ^{*1}	1745 (3847)		1800 (3968)		1830 (4034)		1855 (4089)	
Max payload capacity ^{*2}								
(for tax purposes)	1145 (2524)		1050 (2315)		1070 (2359)		1045 (2303) [1050 (2314)]	
Towing capacity Braked	2700 (5954)		2700 (5954)		3000 (6614)		3100 (6834)	
Unbraked	750 (1654)		750 (1654)		750 (1654)		750 (1654)	
Trailer nose weight	115 (254)		115 (254)		128 (282)		125 (275)	
Servicing/Warranty	Every 9,000 miles or 12 months, whichever occurs first				Every 12,500 miles or 12 months, whichever occurs first			
Service intervals	Every 9,000 miles or 12 months, whichever occurs first				Every 12,500 miles or 12 months, whichever occurs first			
Warranty	5 year/62,500 mile warranty (first 24 months unlimited mileage, thereafter 36 months or 62,500 miles from date of registration, whichever occurs first), 12 year anti-corrosion perforation warranty, 3 year pan-European roadside, home and accident assistance				5 year/62,500 mile warranty (first 24 months unlimited mileage, thereafter 36 months or 62,500 miles from date of registration, whichever occurs first), 12 year anti-corrosion perforation warranty, 3 year pan-European roadside, home and accident assistance			

[] Figures apply to automatic transmission

Important Information: The weights quoted apply to vehicles in standard condition. The operator must ensure compliance with plated axle weights embossed on the vehicle identification plate. ^{*1}Kerb weight excludes an allowance of 75kgs for a driver, but includes the weights of oil, engine coolant, operational fluids, fuel tank filled to 100%, toolkit and spare wheel, as defined by HM Revenue and Customs. ^{*2} Maximum payload capacity as defined by HM Revenue and Customs for VAT purposes.

STANDARD AND OPTIONAL EQUIPMENT

Model	L200 Series 4				NEW L200 Series 5			
	Single Cab 4Life Manual	Club Cab 4Life Manual	Double Cab 4Life Manual	Double Cab Challenger Manual	Double Cab 4Life Manual	Double Cab Titan Manual	Double Cab Warrior Man/Auto	Double Cab Barbarian Man/Auto
Security and Safety Features								
Security								
Immobiliser, engine	■	■	■	■	■	■	■	■
Keyless entry	■	■	■	■	■	■	■	■
Locking wheel nuts	-	-	-	■	■	■	■	■
Rear floor hidden compartment	-	■	-	-	-	-	-	-
Visible VIN	■	■	■	■	■	■	■	■
Safety								
ABS with EBD	■	■	■	■	■	■	■	■
Airbag SRS, driver's and front passenger's	■	■	■	■	■	■	■	■
Airbag SRS, driver's knee protection	-	-	-	-	■	■	■	■
Airbag SRS, front seat side and curtain	-	-	-	-	■	■	■	■
Airbag, front passenger deactivation switch	■	■	■	■	■	■	■	■
Child proof rear door locks	-	-	■	■	■	■	■	■
Daytime running lights	-	-	-	-	■	■	-	-
Daytime running lights, LED type	-	-	-	-	-	-	■	■
Emergency Stop signal System (ESS)	-	-	-	-	■	■	■	■
High-mount stop lamp on tailgate	■	■	■	■	■	■	■	■
Hill Start Assist (HSA)	-	-	-	-	■	■	■	■
ISO-Fix child seat mountings	-	-	■	■	■	■	■	■
Lane Departure Warning (LDW)	-	-	-	-	-	■	■	■
Mitsubishi Active Stability & Traction Control (M-ASTC) with Brake Assist	■	■	■	■	■	■	■	■
Reversing camera	-	-	-	-	-	-	■	■
Seatbelts, 3-point ELR x 2 with force limiters and pretensioners, front	■	■	■	■	■	■	■	■
Seatbelts, 3-point ELR x 2, rear	-	■	-	-	-	-	-	-
Seatbelts, 3-point ELR x 3, rear	-	-	■	■	-	-	-	-
Seatbelts, 3-point ELR x 3, rear (outer with force limiters and pretensioners)	-	-	-	-	■	■	■	■
Side impact door bars	■	■	■	■	■	■	■	■
Speed limiter, adjustable	-	-	-	-	■	■	■	■
Trailer Stability Assist (TSA)	-	-	-	-	■	■	■	■
Exterior Features								
Styling								
16" steel wheels	■	■	■	-	-	-	-	-
16" alloy wheels	DFO	DFO	DFO	-	■	-	-	-
17" alloy wheels	-	-	-	■	-	■	■	■
Door handle recess covers, stainless steel	-	-	-	-	-	-	-	■
Door mirrors and handles, black	■	■	■	-	■	-	-	-
Door mirrors and handles, chrome	-	-	-	■	-	■	■	■
Door mirrors with side indicators	-	-	-	-	-	■	■	■
Front grille, black	■	-	-	-	■	-	-	-
Front grille, chrome	-	■	■	■	-	■	■	-
Front grille, chrome with sports mesh inserts	-	-	-	-	-	-	-	■
Fuel filler cap, stainless steel	-	-	-	DFO	-	-	-	■
Metallic or pearlescent paint finish	□	□	□	□	□	□	□	□
Mudguards, front and rear	■	■	■	■	■	■	■	■
Privacy glass, rear windows	-	-	-	■	-	■	■	■
Rear bumper step, silver	-	-	-	-	-	-	■	■
Rear lamp bezels and tailgate handle trim, chrome finish	-	-	-	DFO	-	-	-	■
Rear under-guard bar, black	■	■	■	■	■	■	■	■
Side steps, straight type	-	■	■	-	-	-	-	-
Side steps, tubular type	-	-	-	■	-	-	-	-
Side steps, tubular type, chrome	-	-	-	-	■	■	■	■
Spare wheel, 16" steel, underfloor-mounted	■	■	■	-	■	-	-	-
Spare wheel, 17" alloy, underfloor-mounted	-	-	-	■	-	■	■	■
Wheelarch extensions, colour-keyed	-	-	-	■	-	■	■	■
Functional								
Differential lock, rear	■	■	■	-	■	-	-	-
Door mirrors, manually adjustable	■	■	■	-	-	-	-	-
Door mirrors, electrically adjustable	-	-	-	-	■	-	-	-
Door mirrors, electrically adjustable/heated/folding	-	-	-	■	-	■	■	■
Fog lamps, front	DFO	DFO	DFO	■	DFO	■	■	■
Halogen headlamps with levelling adjustment	■	■	■	■	■	■	-	-
HID bi-xenon headlamps, wide beam with washers and auto-levelling	-	-	-	-	-	-	■	■
Headlamps, automatic light sensor	-	-	-	■	-	■	■	■
Load bed inner hooks x 6	■	■	■	■	■	■	■	■
Load bed outer hook bars and ladder rack, colour-keyed	■	-	-	-	-	-	-	-
Opening rear quarter windows, butterfly-type	-	■	-	-	-	-	-	-
Skid plate, front, black	■	■	■	■	■	■	■	■
Skid plate, front, silver	-	-	-	-	-	-	■	■
Soft-opening tailgate	-	-	-	-	-	-	-	■
Window demister with timer, rear	■	■	■	■	■	■	■	■
Wipers, automatic rain sensor	-	-	-	■	■	■	■	■
Wipers, variable intermittent with washer, front	■	■	■	■	■	■	■	■

■ : Standard □ : Option at additional cost - : Not available DFO : Dealer Fit Option at additional cost

Model	L200 Series 4				NEW L200 Series 5			
	Single Cab 4Life Manual	Club Cab 4Life Manual	Double Cab 4Life Manual	Double Cab Challenger Manual	Double Cab 4Life Manual	Double Cab Titan Manual	Double Cab Warrior Man/Auto	Double Cab Barbarian Man/Auto
Interior Features								
Audio/Navigation/Communications								
Bluetooth hands-free telephone connection, on steering wheel	■	■	■	■	■	■	■	■
DAB digital radio	-	-	-	DFO	-	■	■	■
Remote audio control, on steering wheel	-	-	-	-	■	■	■	■
SD card navigation system with HD 7" touch-screen display	-	-	-	DFO	-	-	■	■
Stereo radio/CD/MP3 player and 4 speakers	-	-	■	-	■	■	-	-
Stereo radio/CD/MP3 player and 6 speakers	-	-	-	■	-	■	■	■
USB port	-	-	-	-	■	■	■	■
Styling								
Air outlet and transmission panel side trim, silver	-	-	-	-	-	■	■	■
Dashboard centre panel and transmission panel surround, gloss black	-	-	-	-	-	■	■	■
Door entry guards, stainless steel, illuminated Barbarian logo	-	-	-	-	-	-	-	■
Door handles, inner, chrome	-	-	-	-	-	■	■	■
Electric window switch panels, silver	-	-	-	-	-	-	-	-
Electric window switch panels, gloss black/silver	-	-	-	-	-	■	■	■
Gearshift knob, leather-wrapped, black	-	-	-	-	■	■	■	■
Seat trim, two-tone grey fabric	■	■	■	-	■	■	■	-
Seat trim, black leather with Challenger logo	-	-	-	□	-	-	-	-
Seat trim, black leather	-	-	-	-	-	-	■	■
Seat trim, premium black leather with Barbarian logo	-	-	-	-	-	-	-	■
Steering wheel, leather-wrapped, black	-	-	-	■	■	■	■	■
Convenience								
Access support grips, front	-	-	-	-	■	■	■	■
Accessory socket, centre console	■	■	■	■	■	■	■	■
Air conditioning, manual	■	■	■	-	■	-	-	-
Air conditioning, climate control	-	-	-	-	■	-	-	-
Air conditioning, dual-zone climate control	-	-	-	-	-	■	■	■
Door pockets with bottle holder, front	■	■	■	■	■	■	■	■
Door pockets with bottle holder, rear	-	-	-	■	■	■	■	■
Floor console box with lid	-	-	■	■	■	■	■	■
Glove box, illuminated	■	■	■	■	■	■	■	■
Glove box, lockable	-	■	■	■	■	■	■	■
Passenger's assist grip x 1	■	-	-	-	-	-	-	-
Passenger's assist grip x 3	-	■	■	■	■	■	■	■
Passenger's assist grip x 4	-	-	-	-	■	■	■	■
Sunglasses holder	-	-	-	■	■	■	■	■
Sunvisors x 2	■	-	-	-	-	-	-	-
Sunvisors x 2 with driver's ticket holder and passenger's vanity mirror	-	■	■	■	■	■	■	■
Functional								
4WD drivetrain mode indicator	■	■	■	■	■	■	■	■
Auto Stop & Go (AS&G)	-	-	-	-	-	-	-	-
Cruise control	-	-	-	■	■	■	■	■
Door mirrors, manually adjustable	■	■	■	-	-	-	-	-
Door mirrors, electrically adjustable	-	-	-	-	■	-	-	-
Door mirrors, electrically adjustable/heated/folding	-	-	-	-	■	-	■	■
Electric windows with one-touch open/close, front	■	■	■	■	-	-	-	-
Electric windows with one-touch open/close, rear	-	-	■	■	-	-	-	-
Electric window with one-touch open/close, rear cab	-	-	-	■	-	-	-	-
Electric windows, front and rear, with driver's window one-touch open/close and anti-trapping mechanism	-	-	-	-	■	■	■	■
Exterior temperature display	-	-	-	-	■	■	■	■
Keyless operation system with engine start/stop button	-	-	-	-	-	■	■	■
Multi-info display	-	-	-	-	■	■	■	■
Electronic compass, barometer and altimeter	-	-	-	-	■	■	■	■
Steering wheel, tilt adjustable	■	■	■	■	■	■	■	■
Steering wheel, tilt and telescopic adjustments	-	-	-	-	-	■	■	■
Lighting								
Blue LED footwell lighting with puddle lamps	-	-	-	-	-	-	-	■
Interior lamp	■	■	■	■	■	■	■	■
Map reading lamps, front	-	-	■	■	■	■	■	■
Seats								
Armrest, front centre	■	■	■	■	■	■	■	■
Armrest, rear centre with cup holders	-	-	-	■	■	■	■	■
Head restraints, height adjustable, front x 2	■	■	■	■	■	■	■	■
Head restraints x 2, rear	-	■	■	-	-	-	-	-
Head restraints x 3, rear	-	-	-	■	■	■	■	■
Seats, front – driver's height adjuster	-	-	-	■	■	■	■	■
Seats, front – passenger's seat easy-entry rear access	-	■	-	-	-	-	-	-
Seats, front – driver's powered and 2 x heated seats	-	-	-	-	-	-	■	■
Seats, front – slide and recline adjustments	■	■	■	■	■	■	■	■
Seats, front – seatbelt height adjustment	-	■	■	■	■	■	■	■
Seats, rear – fold-up cushions x 2	-	■	-	-	-	-	-	-

COLOUR OPTIONS AND SEAT TRIMS



STARLIGHT SILVER (M)



ELECTRIC BLUE (M)



AMAZON GREEN (M)



ATLANTIC GREY (M)



STERLING SILVER (M)



GRANITE BROWN (M)



AZTEC RED (S)



SAPPHIRE BLUE (M)



POLAR WHITE (S)



COSMOS BLACK (P)

Model	L200 Series 4				NEW L200 Series 5			
	Single Cab 4Life	Club Cab 4Life	Double Cab 4Life	Double Cab Challenger	Double Cab 4Life	Double Cab Titan	Double Cab Warrior	Double Cab Barbarian
Exterior colour								
Starlight Silver (M)	A66	■	■	■	-	-	-	-
Electric Blue (M)	D23	-	-	-	-	■	■	■
Amazon Green (M)	F27	-	-	-	■	■	■	■
Atlantic Grey (M)	U17	-	■	■	-	■	■	■
Sterling Silver (M)	U25	-	-	-	■	■	■	■
Granite Brown (M)	C06	-	-	-	-	-	-	-
Aztec Red (S)	R59	■	■	■	■	■	■	■
Sapphire Blue (P)	T64	-	-	-	-	-	-	-
Polar White (S)	W32	■	■	■	■	■	■	■
Cosmos Black (P)	X08	■	■	■	■	■	■	■
Seats	Fabric (Dark Grey)	Fabric (Dark Grey)	Fabric (Dark Grey)	Fabric (Dark Grey) or Leather (Black)	Fabric (Dark Grey)	Fabric (Dark Grey)	Leather (Black)	Leather (Black)
Door trim	Resin (Grey)	Resin (Grey)	Resin (Grey)	Resin (Grey)	Resin (Black/Grey)	Resin (Black/Grey) with Fabric Inserts	Resin (Black/Grey) With Leather-look Inserts	Resin (Black/Grey)
Headlining	Non-woven Fabric (Grey)				Non-woven Fabric (Grey)			
Floor carpet	Needle Punch (Grey)				Needle Punch (Grey)			

■ : Available - : Not available M: Metallic* P: Pearlescent* S: Solid *Metallic/pearlescent paint finish available at additional cost. Colours and trims reproduced on these pages may vary from the actual colours due to the limitations of the printing process used.

Seat Trims

NEW L200 Series 5



DARK GREY FABRIC (4LIFE)



DARK GREY FABRIC (TITAN)



BLACK LEATHER (WARRIOR)



BLACK LEATHER (BARBARIAN)

L200 Series 4

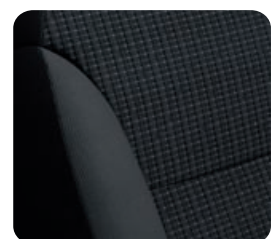

DARK GREY FABRIC (4LIFE)

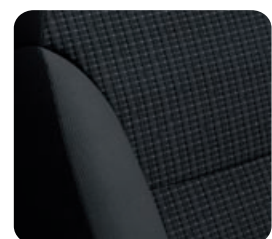

DARK GREY FABRIC (CHALLENGER)



BLACK LEATHER (OPTION FOR CHALLENGER)

DIMENSIONAL VIEWS

L200 Series 4 Single Cab

All measurements in millimetres.

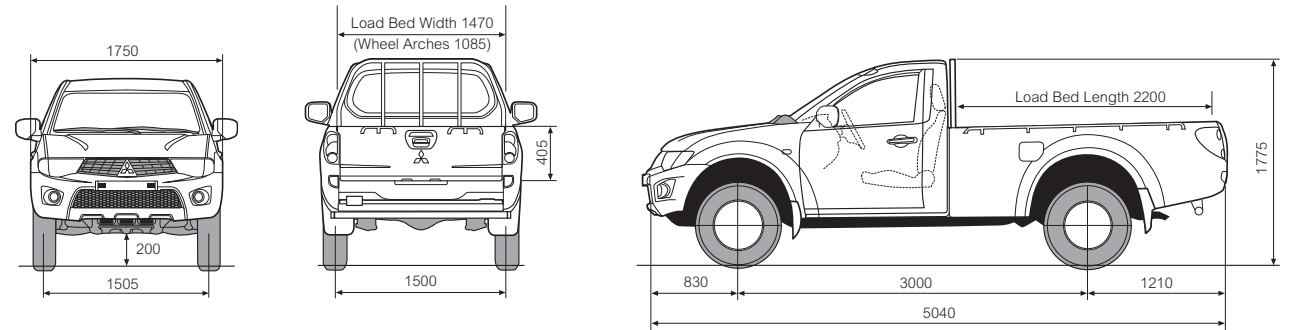

L200 Series 4 Club Cab

All measurements in millimetres.

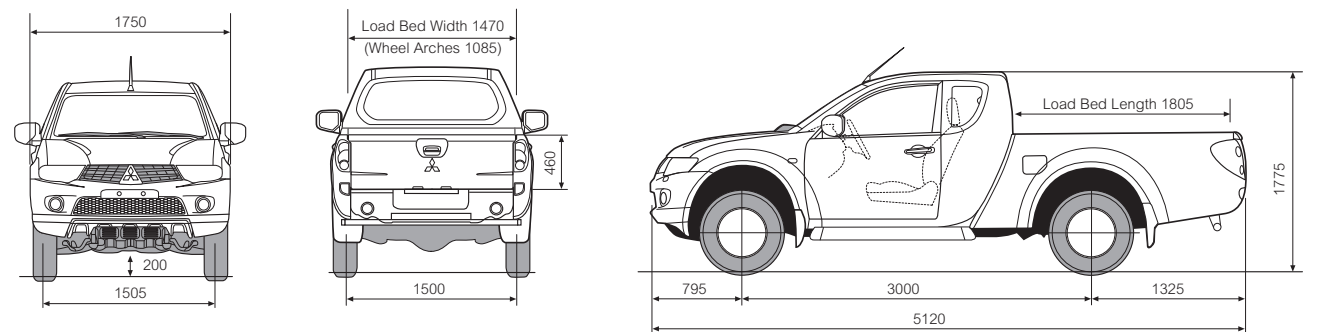

L200 Series 4 Double Cab

All measurements in millimetres. () Challenger

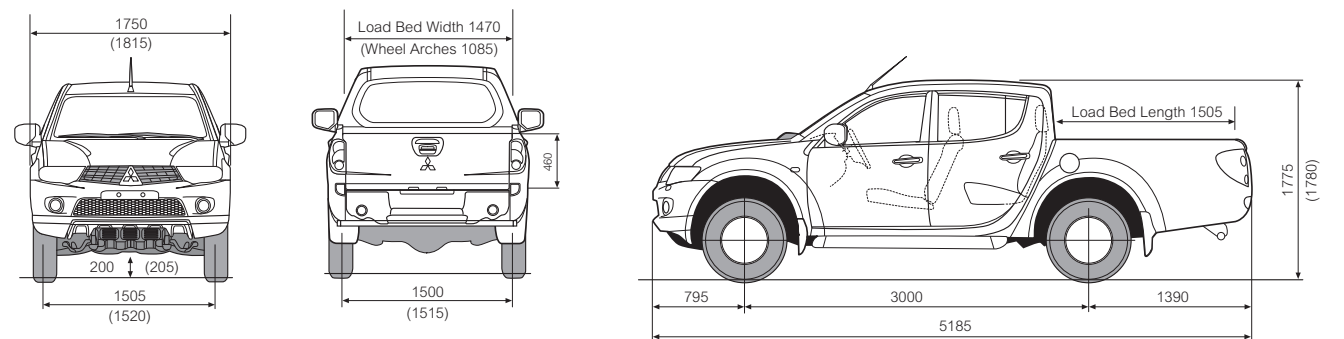

NEW L200 Series 5 Double Cab

All measurements in millimetres. *14Life / *24Life/Titan

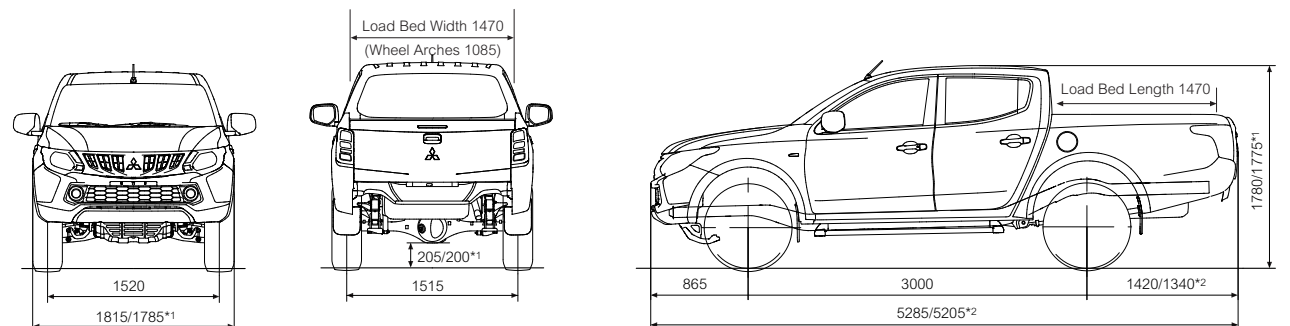

MITSUBISHI MOTORS RECYCLING

We all have a duty to protect the environment. After a long working life we will take back any Mitsubishi Motors vehicle originally sold by The Colt Car Company Ltd. and recycle it in an environmentally friendly manner in accordance with the EU Directive on End-of-Life Vehicles and any applicable national statutory provisions.

All Mitsubishi Motors vehicles sold by The Colt Car Company Ltd., irrespective of date of sale, will be taken back free of charge from the last owner, at one of the designated take-back points, provided the vehicle contains all major components and is free of waste.

For further information please visit www.cartakeback.com, email info@cartakeback.com or call the Cartakeback info-line on 0845 257 32 33.

The specification of the vehicles illustrated in this publication may not be applicable to the UK market, furthermore some vehicle illustrations may include accessory items which are not part of UK standard specification. However, every effort has been made to ensure that the written information was accurate, up-to-date and consistent with UK specification at the time of going to press. The right is reserved to change specification, features and prices without prior notice. To avoid any misunderstandings, your Mitsubishi Motors dealer will advise of any alterations made since the date of issue of this brochure. No part of this publication may be reproduced in any form or by any means, without the prior written permission of The Colt Car Company Limited.

Head Office: The Colt Car Company Ltd., Watermoor, Cirencester, Glos. GL7 1LF
Website: www.mitsubishi-cars.co.uk



This brochure has been produced by an ISO14001 environmentally accredited printer where all processes are managed and materials recycled. The paper used to produce this brochure is from sustainable forests, chlorine free and from an ISO14001 accredited mill. This brochure is fully recyclable.