

RENAULT KANGOO

E-Tech Electric



15th December 2021





Efficient, adaptable and durable

The Renault Kangoo E-Tech has been specifically designed with your needs in mind, whatever your business environment. With a broad range of options and accessories available, the Kangoo can be adapted to your every demand, offering you tailor made and practical solutions.



Dashboard storage compartment

Electrically operated door mirrors

Manual air-conditioning*

USB and AUX ports

Height adjustable steering wheel

Central storage console*

DAB radio and Bluetooth^

Electric front windows

Image shows a diesel version. Electric interior may vary.

Giving you assistance and control

Here at Renault, nothing is more important to us than your safety and comfort which is why our range of driving assistance systems is more innovative than ever and most come as standard on all our vans!

Rear Parking Sensors

Parking made all that bit easier with sensors alerting you when your getting close to what's behind you!

Hill Start Assist

No more tricky hill starts as your van will hold you for a couple of seconds to ensure you have time to pull off in gear



16" Steel wheels with large stylers

Electronic Stability Control

Helps keep you stable in the Kangoo, even when faced with extreme driving conditions

[^]For compatible devices, please refer to <https://www.renault.co.uk/services/multimedia/bluetooth-compatibility.html>

**R-LINK not currently available to order



Ergonomic and comfortable workspace

Renault has developed clever solutions to increase practicality whilst improving safety. Kangoo E-Tech has optimal visibility and ergonomic controls which create a car-like driving position without sacrificing on cabin storage solutions.







Cutting emissions and your costs

Our Kangoo E-Tech is 100% electric, offering you ultra-low running costs without sacrifice. The quiet yet instant pulling power means your Kangoo E-Tech is simply a pleasure to drive, bringing enjoyment to each journey. Kangoo's impressive 143 mile range further allows you to drive without stress, with the Wallbox* providing an easy to charge solution at home or work.

* Wallbox not included in purchase

Renault E-Tech electric

Always a step ahead

Renault has been pushing the boundaries of innovation from revealing the Z.E concept car in 2008, and since then has been a leader in electric vehicle manufacturing in Europe. It has been a priority to fulfil our commitment and continue to develop our technology so that our vehicles stay at the forefront of the electric vehicle market.

First place on the track - first choice on the road

Our commitment to electric motoring innovation runs deeply in Renault's brand DNA. We were a founding partner in Formula E™, the FIA's newest race series. Winning the team championship in 2014/15 and 2015/16 seasons, along with the driver's championship in 2015/16, proves superior electric technology on the track and as one of Europe's best selling EV brands on the road.

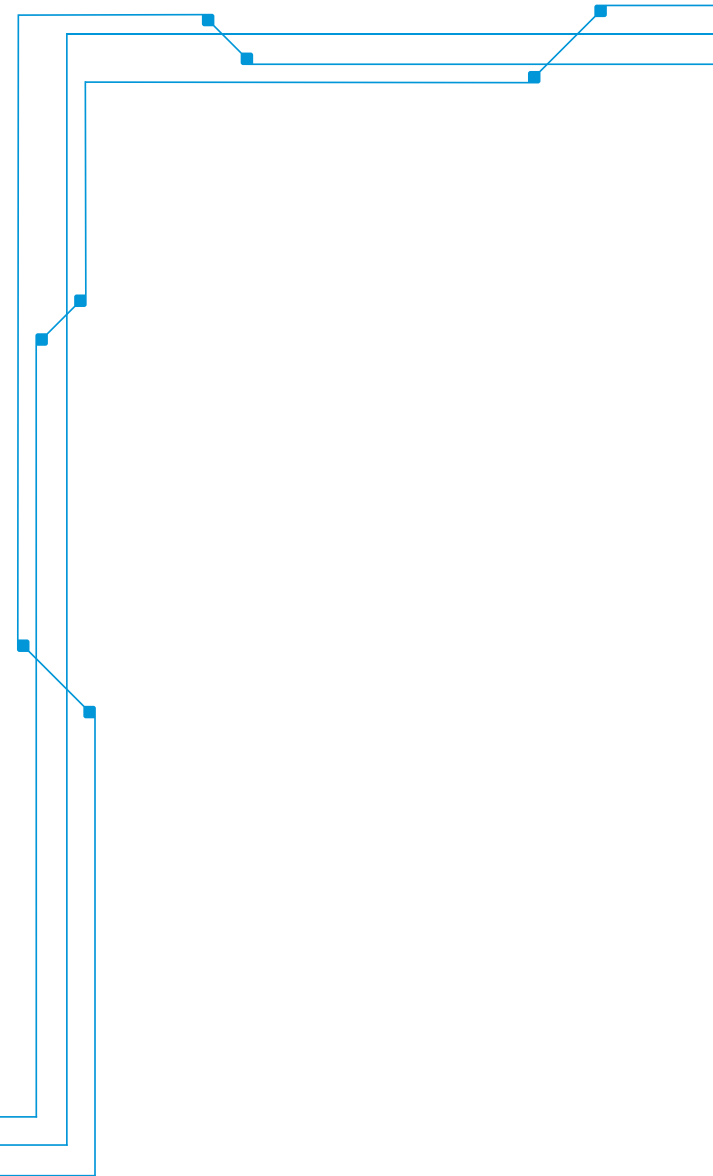

Easy Electric Life

Electric mobility does not have to be more complicated than fuel-powered vehicles.

Far from it, electric power comes as second nature in most areas of our lives - have you ever thought about filling up your smartphone with fuel? Your van does not need to be any different from your phone, simply put it on charge.

Renault PRO+ Electric Vans

Electric isn't just the future, it's right now. That's why our customers have been driving electric vehicles since 2011, and we've since developed the largest model range of electric LCVs in the UK. For you and your business, the result is key. So you'll be pleased to hear that with a Renault PRO+ electric van, you could make significant savings compared to running a diesel or petrol van. Plus, with over 35,000 charging points in the UK, isn't it time for you to join the electric revolution?

It's in our nature

Through supplying the Eden Project in Cornwall with a fleet of 3 Zoe, 13 Kangoo E-Tech electric and 4 Twizy, we are supporting them in their mission to connect people with each other and the living world, exploring how we can work together towards a better future.

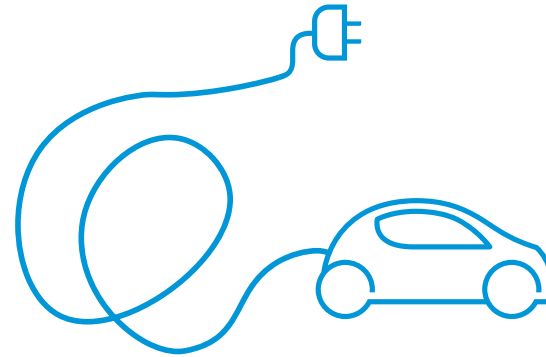



Your 100% controlled driving range



Kangoo E-Tech has 143 miles⁽¹⁾ of driving range in actual use thanks to its lithium-ion E-Tech electric (33 kWh) battery. The 44 kW power unit offers a torque of 225 Nm and optimum driving comfort. A range of on-board technologies, such as regenerative braking (the battery recharges when the accelerator pedal is released or when the brake pedal is pressed) or the Eco mode (less abrupt acceleration and maximum speed of 50 mph), help optimise your driving range. You can charge your Kangoo E-Tech in just 6 hours with a 32 A/7 kW Wallbox. The recharging flap located on the nose of the vehicle, is easily accessible.

(1) Real-world driving range greater than 75 miles including the most severe use (high load, city centre driving with frequent stops and winter conditions). Actual consumption also depends on the equipment, the driving style of the driver and the elevation profile of the route.



1. Regenerative braking. The battery recharges when you take your foot off the accelerator or when you press on the brake pedal.

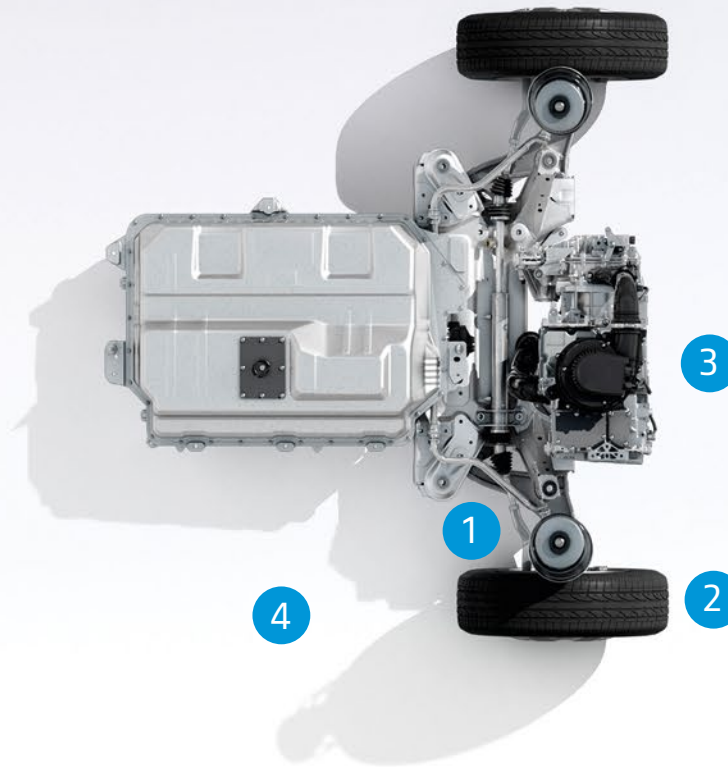

2. Low consumption tyres. Their low rolling resistance contributes to conserving your driving range without degrading your road-holding or braking ability.

3. Eco mode. When you activate this, you reduce the power output of the vehicle so that you can travel further (less abrupt acceleration and maximum speed of 50 mph).

4. 7 kW charger. Recharge the battery in just 6 hours with a 32A/7 kW Wallbox. The recharging flap located on the right-hand side of the cab, is easily accessible.

Driving range

Kangoo E-Tech is now available with the E-Tech electric Battery giving a revolutionary WLTP* range of 199 miles (city cycle) on one charge, meaning range anxiety is a thing of the past. With real life estimates of 124 miles in summer and 75 miles in winter** the Kangoo E-Tech is able to get you wherever you need to go with less need to recharge on the way, saving you time and money.

WLTP range* Combined cycle (miles)	WLTP range* City cycle (miles)	Summer (+20°C)	Winter** (-5°C)	Cost in Pence p/per mile†	Cost per full recharge†
143	199	124	75	Less than 4p	Less than £5

Top tip: Need an extra boost to get home? The Kangoo charges 15-21 miles on just an hour of charge.

*What is WLTP and why the real-life range is similar to it?

Worldwide Harmonized Light Vehicles Test Procedures (WLTP), this new homologation protocol gives fuel consumption and driving range results that are much closer to real life conditions figures than the NEDC protocol. While the old NEDC test determined test values based on a theoretical driving profile, the WLTP cycle was developed using real-driving data, gathered from around the world. WLTP therefore better represents everyday driving profiles.

**Why is the range reduced in winter?

Like all batteries, those in E-Tech electric vehicles are less efficient in cold weather than at warmer ambient temperatures. This means that you can expect a reduction in the range of your Renault E-Tech electric in the winter. Also, in winter you are more likely to use the heating, which means Kangoo E-Tech consumes more energy.

Choose the charging solution for you

Type of charger	Where to use it	Power required	Charging times (0-100%)	
Home (3-pin plug cable)*	Home / Office	2.3kW/10A	17 hours	Occasional slow charging. *Requires additional purchase of a EVSE cable.
	Home / Office	3.3kW/14A	12 hours	
Wallbox / Public charging point	Home / Office / On the go	3.7kW	11 hours	Leaving the Kangoo to charge overnight on a 3.7kW charger ensures that it will be ready for when you to begin your next day.
	Home / Office / On the go	7kW	6 hours	
Public charging point	On the go	22kW	6 hours	A standard charging time of 6 hours means your vehicle is ready to go when you are.
	On the go	43kW	6 hours	

†Less than £5 full recharge cost based on 6 hours of 14.4p per kWh (Source: UK Power) Full recharge of the 33 kWh battery
(1) For illustration purposes only, may not reflect real-life journeys.

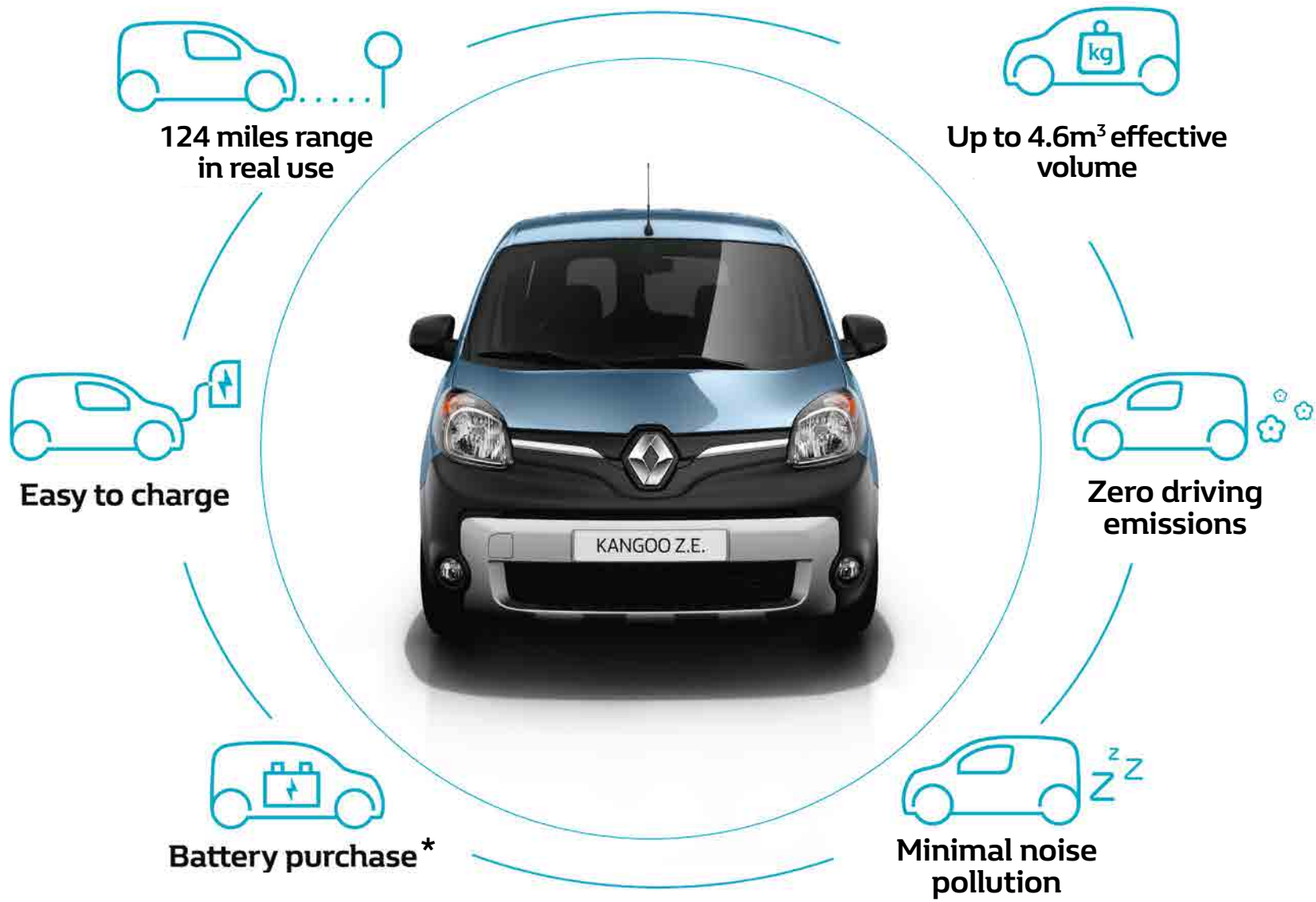

**124 miles range
in real use**

**Up to 4.6m³ effective
volume**

**Zero driving
emissions**

**Minimal noise
pollution**

Battery purchase*

Easy to charge

KANGOO Z.E.

*Battery guarantee of 5 years / 62,000 miles, whichever comes first, this includes the battery performance guarantee to at least 70% of its original capacity.



Standard features

BUSINESS



15" BRIGANTIN wheels



TANEGA Upholstery



THE BASICS:

- Front E-Tech electric charging socket
- Standard charging cable 32A (IEC 629196 - Type 2 Mennekes) 6m
- Electrically operated door mirrors
- Electric front windows
- Height adjustable steering wheel
- ABS with EBD (Electronic Brake Force Distribution)
- Alarm (perimeter)
- Height adjustable drivers seat
- Deadlocking
- R.A.I.D (Renault Anti Intruder Device)
- ESC (Electronic Stability Control) with Hill Start Assist
- Front and rear disc brakes*

MAKING YOUR JOURNEY COMFORTABLE:

- Central storage tray between front seats
- A4 storage in dashboard

WHAT YOUR VAN LOOKS LIKE:

- 15" BRIGANTIN wheels
- Dark grey side protection mouldings
- Front and rear dark grey bumpers
- Unglazed 180° asymmetric rear doors
- Unglazed side loading door – left side (Kangoo Van) / left and right side (Kangoo Maxi)

PROTECTING YOU AND YOUR LOAD:

- Anchorage points in load area – 6 on Kangoo and 14 on Kangoo Maxi
- Weight allowed per anchorage point: approximately 500kg
- Full steel bulkhead
- Tyre repair system

KEEPING YOU CONNECTED:

- 2x15W DAB radio with AUX input, CD, Bluetooth^{®†} and USB connectivity
- Eco mode function
- 12V power socket (front)
- E.V. Voice (pedestrian safety alert)

* For ML19 ENERGY dCi 80, dCi 95 and dCi 115 versions rear drum brakes are fitted as standard.

† For compatible devices, please refer to <https://www.renault.co.uk/services/multimedia/bluetooth-compatibility.html>

Standard features

BUSINESS+ (additional equipment to Business)



15" BRIGANTIN wheels



TANEGA Upholstery



MAKING YOUR JOURNEY COMFORTABLE:

- Electrically operated and folding door mirrors
- Electric front windows (driver's side one-touch descending)
- Centre console with armrest
- Overhead parcel shelf
- Load area rubber floor covering
- Rear parking sensors
- Metallic Paint

PROTECTING YOU AND YOUR LOAD:

- Front and rear body coloured bumpers and gloss black wing mirrors

Colours



MINERAL WHITE ⁽¹⁾
(QNG)



CARMEN RED ^{(1) (3) (4)}
(719)



URBAN GREY ^{(1) (3) (4)}
(KPW)



JET BLACK ⁽²⁾
(GND)



MOCHA ⁽²⁾
(CNB)



HIGHLAND GREY ⁽²⁾
(KQA)



OYSTER GREY ⁽²⁾
(KNG)

- (1) Non metallic paint
- (2) Metallic paint
- (3) Not available with front and rear body coloured bumpers
- (4) Kangoo Business+ must be ordered with Sport front bumper with silver insert and Front fog lights

Mineral White
QNG

Carmen Red
719

Urban Grey
KPW

Jet Black
GND

Mocha
CNB

Highland Grey
KQA

Oyster Grey
KNG

Business E-Tech	●	●	●	○	○	○	○
Business+ E-Tech	●	●	●	●	●	●	●

● = Standard (therefore no cost) ○ = Optional - = Not available It should be noted that printing limitations do not permit the subtle paintwork shades on these pages to be shown with absolute accuracy.

Wheels and Tyres

E-Tech electric	
TYPE OF TYRES	Summer
Tyre/wheel size	195/65 R15
Make	Michelin Extra Load Energy Saver +
Fuel efficiency class	C
Wet grip class	B
Exterior noise (dB)	

Kangoo E-Tech pricing

To make Kangoo E-Tech ownership as easy as possible, all Kangoo E-Tech now come with the battery included.

Kangoo E-Tech - Battery Purchase

- No on-going monthly payments, just one simple payment.
- No mileage limit in the battery contract.
- Battery guarantee*** of 5 years / 62,000 miles, whichever comes first, this includes the battery performance guarantee to at least 70% of its original capacity.
- Roadside assistance, breakdown only

KANGOO VAN E-TECH ELECTRIC

VERSIONS	WLTP CO ₂ (g/km)	Power unit output kW (bhp)	Load volume (m ³)	Max. payload (kg) [†]	Basic price (£)	VAT 20% (£)	Total retail (£)*	Government grant (£)	Basic price after PiVG* exc VAT	Total retail price after PiVG**	On the road price after PiVG***
PANEL VAN BUSINESS											
L2H1											
ML20 E-Tech electric Business	0	44 (60)	3.0	625	26,000	5,200	31,200	2,500	£23,500	£28,700	£29,391
L3H1											
LL21 E-Tech electric Business	0	44 (60)	4.0	605	27,500	5,500	33,000	2,500	£25,000	£30,500	£31,191
PANEL VAN BUSINESS +											
L2H1											
ML20 E-Tech electric Business+	0	44 (60)	3.0	625	26,600	5,320	31,920	2,500	£24,100	£29,420	£30,111
L3H1											
LL21 E-Tech electric Business+	0	44 (60)	4.0	605	28,100	5,620	33,720	2,500	£25,600	£31,220	£31,911

* PiVG - Plug-In Van Grant. ** All prices shown are the manufacturer's recommended retail prices. i - Indicates with full battery purchase. ***For full terms and conditions visit www.renault.co.uk/warranty. The "On The Road" price includes delivery to the dealer premises, 35% PiVG (up to a maximum of £2,500 for small vans weighing less than 2.5 tonnes), number plates, 12 months government road fund licence at £275 (or £0 for Kangoo E-Tech) and First Registration Fee at £55. Other goods or services supplied by agreement between the customer and the Dealer are not included. † Payload equals the Maximum Operating Mass (Gross Vehicle Mass or GVW) less the Kerb Mass. Kerb Mass is the weight of the complete vehicle including coolant, oil, the battery, spare wheel and jack, but excluding driver and crew. All Kerb Masses, and therefore Payloads quoted are subject to a 5% manufacturing tolerance and are based on the base level model. Any additional equipment added (options or accessories), or the selection of a higher trim level, could result in a higher Kerb Mass and a reduced Payload, and may increase weight and decrease range figures.

LCV SERVICE PLAN

5 Years / 66,000 miles

MRRP (inc VAT)

£750

LCV EXTENDED WARRANTY

5 Years / 96,000 miles

MRRP (inc VAT)

£540

Service Plan Terms & Conditions The Service Plan offer is available on all LCV's. Valid at participating Renault dealers only and may be purchased up to 12 months after registration or before the first service (whichever is sooner). Vehicles must be ordered between 01 December 2021 and 31 March 2022 and registered by 30 June 2022.

The Renault Service plan covers the manufacturer's minimum maintenance programme requirements for the term of the Service Plan purchased (refer to the Warranty and Service sheet in the Handover Document wallet for details). The plan ends when you reach the age or mileage limit (whichever comes first). Services must be carried out in line with the manufacturer's minimum maintenance programme requirements and servicing intervals within +/-1 month or 1,000 miles of the service interval and can only be carried out at a Renault Approved outlet. Service plans do not cover wear and tear items such as (but not limited to) tyres, wiper blades or brakes. For Service plan full Terms & Conditions visit www.renault.co.uk/owners. Cannot be part exchanged, refunded or transferred. All prices quoted are MRRP.

Extended Warranty Terms & Conditions The Extended Warranties are available on all LCV's (excluding ZOE Van). Valid at participating Renault dealers only and are available to purchase from first date of registration and may be purchased up to 12 months after registration. For full Extended Warranty Terms and Conditions visit www.renault.co.uk/extensions-of-warranties

Kangoo E-Tech options pricing

	BUSINESS E-Tech		BUSINESS+ E-Tech		Basic price (£)	VAT 20% (£)	MRRP*
	MWB	LWB	MWB	LWB			
BASICS							
Interior side door panel	○	○	○	○	80	16	£96
Tyre repair kit	○	-	○	-	No cost option		
Additional heating unit ⁽¹⁾	○	○	○	○	900	180	£1,080
EVSE Cable for 10 amp charging for domestic 3-pin plug	○	○	○	○	415	83	£498
SAFETY							
Airbag - front passenger ⁽²⁾	○	○	○	○	235	47	£282
Airbag - front lateral (thorax) & front passenger	○	○	○	○	385	77	£462
2 additional Anchorage points in load area, weight allowed per anchorage point: approximately 500kg	○	●	○	●	75	15	£90
Automatic headlights and wipers with front fog lights	○	○	○	○	210	42	£252
Bulkhead - swivelling with folding passenger seat	○	○	○	○	230	46	£276
Bulkhead - tubular	○	○	○	○	No cost option		
Front fog lights	○	○	○	○	150	30	£180
Load area rubber floor covering	○	○	●	●	95	15	£90
COMFORT							
Central console with plastic armrest	○	○	●	●	50	10	£60
Cruise control with speed limiter	○	○	○	○	210	42	£252
Electric front windows - driver's side one-touch descending	○	○	●	●	50	10	£60
Engine speed limiter (56mph OR 62mph OR 68mph)	○	○	○	○	65	13	£78
Leather steering wheel	-	-	○	○	60	12	£72
Overhead parcel shelf	○	○	●	●	75	15	£90
Rear parking sensors	○	○	●	●	220	44	£264
Smoker pack	○	○	○	○	20	4	£24
Manual air conditioning and pollen filter with heat pump	○	○	○	○	1,200	240	£1,440
STYLE							
Metallic paint	○	○	●	●	450	90	£540
Sport front bumper with silver insert ⁽³⁾⁽⁴⁾	○	○	○	○	50	10	£60
Standard bumper	●	●	○	○	No cost option		

● = Standard (therefore no cost) ○ = Optional - = Not available †Manufacturer's recommended retail prices.

(1) Not compatible with multipositional bulkhead (2) Can be deactivated (3) Must be taken with front fog lights (4) Not compatible with body-coloured bumper

Doors and windows

KANGOO E-Tech electric

	MWB	LWB	Basic price (£)	VAT 20% (£)	MRRP*
Right side loading door - unglazed	-	●	200	40	£240
Glazing for left and right side loading doors non opening windows each (for both sides)	-	○	50 (100)	10 (20)	£60 (120)
Opening windows for left and right glazed side loading doors	-	-	50	10	£60
Glazed rear quarter panels	-	○	75	15	£90
Rear doors - 180° glazed with rear wipers and rear heated window	○	○	200	40	£240

● = Standard (therefore no cost) ○ = Optional - = Not available * All prices shown are the manufacturer's recommended retail prices.



Dimensions - Kangoo E-Tech

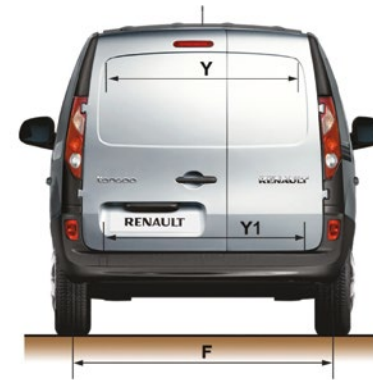
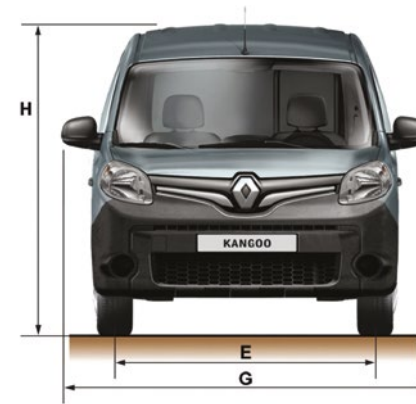
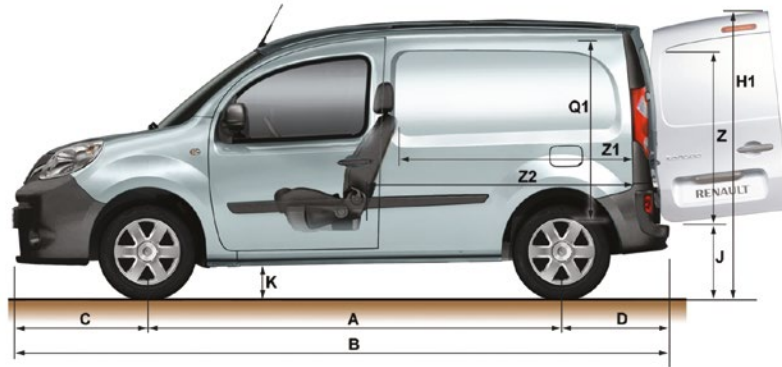

DIMENSIONS (mm)

Payload electric	625kg
Load volume electric	3.6m ³ [^]
A Wheelbase	2,697
B Overall length	4,282
C Front overhang	875
D Rear overhang	710
E Front track width	1,521
F Rear track width	1,534
G Overall width (without mirrors)	1,829
G1 Overall width (with mirrors)	2,138
H Unladen height	1,805 to 1,844
H1 Height with opened rear doors	1,872 to 1,934

J Sill Height	588 to 609
K Ground Clearance (unladen)	157 to 210
K1 Ground Clearance (laden)	143 to 172
M Elbow room	1,510
N Front interior width	1,464
Q1 Rear interior height	1,251
Y Rear width- top	1,141
Y1 Rear width-bottom	1,219
Y2 Width between wheel arches	1,218
Z Loading height	1,129
Z1 Loading length	1,476
Z2 Loading length at floor / with option folding passenger seat	1,731 / 2,502

[^]Payload equals the Maximum Operating Mass (Gross Vehicle Mass or GVW) less the Kerb Mass, Kerb Mass is the weight of the complete vehicle including coolant, oil, a 90% full fuel tank, spare wheel and jack, but excluding driver and crew. All Kerb Masses, and therefore Payloads quoted are subject to a 5% manufacturing tolerance and are based on the base level model. Any additional equipment added (options or accessories), or the selection of a higher trim level, can result in a higher Kerb Mass and reduced Payload, and may increase CO₂ and decrease MPG figures.

Dimensions - Kangoo Maxi E-Tech

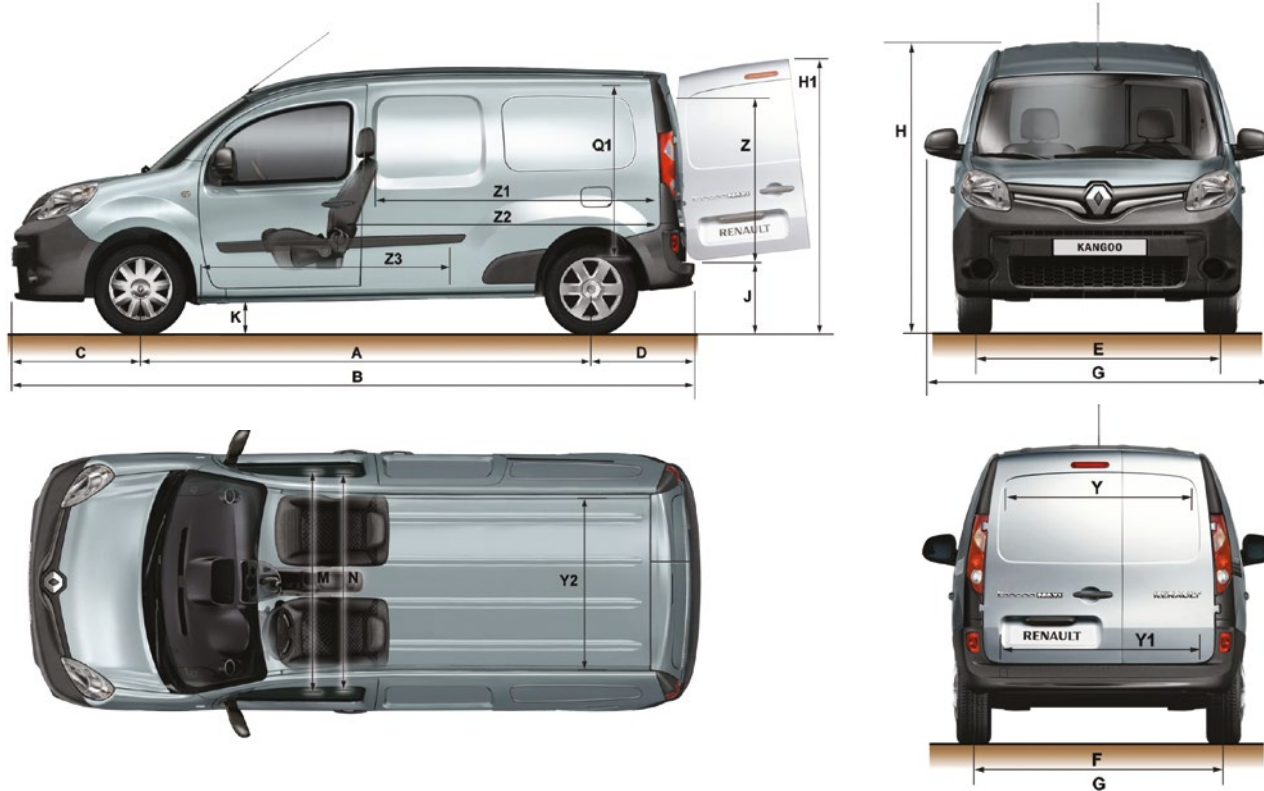

DIMENSIONS (mm)

Maxi Panel Van

Average Payload electric	605kg
Load volume electric	4.6m ³
A Wheelbase	3,081
B Overall length	4,666
C Front overhang	875
D Rear overhang	710
E Front track width	1,521
F Rear track width	1,533
G Overall width (without mirrors)	1,829
G1 Overall width (with mirrors)	2,138
H Unladen height	1,810 to 1,836
H1 Height with opened rear doors	1,893 to 1,920

J Sill Height	575 to 601
K Ground Clearance (unladen)	170 to 212
K1 Ground clearance (laden)	145 to 172
M Elbow room (front/rear)	1,510/ -
N Front interior width (front/rear)	1,464/ -
Q1 Rear interior height	1,252
Y Rear width- top	1,141
Y1 Rear width-bottom	1,219
Y2 Width between wheel arches	1,218
Z Loading height	1,129
Z1 Loading length	1,862
Z2 Loading length at floor / with option folding passenger seat	2,115 / 2,886

^APayload equals the Maximum Operating Mass (Gross Vehicle Mass or GVW) less the Kerb Mass. Kerb Mass is the weight of the complete vehicle including coolant, oil, a 90% full fuel tank, spare wheel and jack, but excluding driver and crew. All Kerb Masses, and therefore Payloads quoted are subject to a 5% manufacturing tolerance and are based on the base level model. Any additional equipment added (options or accessories), or the selection of a higher trim level, can result in a higher Kerb Mass and reduced Payload, and may increase CO₂ and decrease MPG figures.

Technical Specifications - Kangoo E-Tech

KANGOO VAN E-TECH ELECTRIC

KANGOO MAXI E-TECH ELECTRIC

BATTERY

Battery type	Lithium-Nickel-Manganese-Cobalt (LiMnCoO)		
Battery weight (kg)	260kg		
Fuel type	Electric		
Max engine power kW (hp)	44 Kw / 60 hp		
Max Torque (nm)	225		

RANGE

Range (NEDC) miles	170		
Range (WLTP) miles	143		
Range in temperate conditions (+20°C) (miles/km)	124 / 199		
Extreme winter conditions (-5°C) (miles/km)	75 / 120		
Extreme winter conditions (-5°C) with air-con & heat pump (miles/km)	84 / 135		
Extreme winter conditions (-5°C) with external heater (with or without air-con & heat pump) (miles/km)	99 / 160		

DRIVE TRAIN

Type	Traction		
Motor and drive train features	Synchronous with rotor coil		

TYRES

Tyre size	195/65 R15 95T (Energy Saver)		
-----------	----------------------------------	--	--

BREAKING SYSTEM

Front disc brakes (mm) (diameter/thickness)	280/24		
Rear disc brakes (mm) (diameter/thickness)	274/11		

PERFORMANCE

Maximum Speed mph	81		
0-62mph (sec)	20.6		22.3

FUEL CONSUMPTION*

Electricity consumption (kWh/mi)	245		
----------------------------------	-----	--	--

BATTERY CAPACITY

Battery Capacity (kWh)	33		
------------------------	----	--	--

WEIGHT (KG)

Kerb weight - empty without option	1505		1585
Gross vehicle weight	2130		2190
Payload [^]	625		605
Roof payload		100	
Unbraked trailer (kg)	375		322
Braked trailer (kg)	375		322

SERVICING INTERVALS

Service Intervals	E-Tech electric Services - 1st Year / 12,000 miles 2nd Year / 24,000 miles then every 24,000 miles or 2 years after that		
-------------------	--	--	--

WARRANTY

Warranty	Warranty and road side assistance ; 3 Years. Unlimited for first 24 months, then limited to a total of 100,000 miles or 3 years, whichever comes first		
----------	--	--	--

*WLTP figures shown are for comparability purposes; only compare figures with vehicles tested to the same technical procedures. Actual real world driving results may vary depending on factors such as weather conditions, driving styles, vehicle load or any accessories fitted after registration. WLTP is a new test used for fuel consumption and CO₂ figures. Please visit renault.co.uk/configure for WLTP figures for any selected options. [^]Payload equals the Maximum Operating Mass (Gross Vehicle Mass or GVW) less the Kerb Mass. Kerb Mass is the weight of the complete vehicle including coolant, oil, spare wheel and jack, but excluding driver and crew. All Kerb Masses, and therefore Payloads quoted are subject to a 5% manufacturing tolerance and are based on the base level model. Any additional equipment added (options or accessories), or the selection of a higher trim level, could result in a higher Kerb Mass and a reduced Payload, and may increase CO₂ and decrease MPG figures.

Accessories

Kangoo Van comes equipped with a full height steel bulkhead as standard



1. Ply lining

Protect the interior of your new Kangoo with our hardwearing, bespoke Ply Lining. The price includes fitment by Renault.

2. Kenwood Dashcam

The Kenwood DVR-A501W dashcam is a great addition for added security and reassurance on the road.

3. 3-Pin Domestic Charging Cable

Keep your Kangoo E-Tech electric charged at a standard socket, no need to worry about having to charge without a charging station.

4. Roof Bars

Very practical for transporting professional equipment and all other bulky loads. These roof bars meet all safety and quality standards.

5. Rear Body Coloured Parking Sensors

Allows you to park with confidence. Not compatible with factory fit rear parking sensors.

Some accessories require the vehicle to be registered before fitment. Your local dealer will be able to offer further advice and supply a dealer fitted price for vehicles already in dealer stock. Accessories are fitted post production and may have an impact on real world fuel (actual) consumption and CO₂ figures.

For more information and additional accessories, consult the Kangoo accessories brochure.



2.



3.



4.



5.

Kangoo E-Tech accessory pricing

	Basic price (£)	MRRP*
CHEVRONS		
Full rear chevrons	366.67	£440
Full rear chevrons without window panel	250	£300
Lower half height chevrons	241.67	£290
SAFETY		
Deadlock kit - front door	150	£180
Deadlock kit - passenger front door	150	£180
Deadlock kit - side loading door	150	£180
Deadlock kit - passenger side side loading door	150	£180
Deadlock kit - glazed side loading door	150	£180
Deadlock kit - glazed passenger side side loading door	150	£180
Deadlock kit - rear door	150	£180
Deadlock 4 door set - driver, passenger, side loading, rear doors	415.83	£650
Deadlock 2 door set - side loading, rear doors	258.33	£310
Slamlock 2 door set - side loading, rear doors	220	£264
Protektaplate 4 door set - driver, passenger, side loading, rear doors	300	£360
Protektaplate 2 door set - side loading, rear doors	230	£276
Armourshell 2 door mini set - side loading, rear door - black	340	£408
Alarm	183.33	£220
Kenwood dashcam	208.33	£245
MULTIMEDIA		
Focal music speakers 4.0	180	£216
TRANSPORT & TOWING		
Transversal roof bars	140	£168
Roof rack L1	325	£390
Roof rack L2	458.33	£550
Towing kit - fixed tow bar and wiring loom	271.67	£326
READY 4 WORK		
Standard storage system – includes standard offside racking with safety floor	829.17	£995
PROTECTION		
Ply lining - Kangoo van MWB	140.83	£169
Ply lining - Kangoo van LWB	149.17	£179
Ply lining - Kangoo crew van LWB	140.83	£169
Ply lining - Kangoo E-Tech electric MWB	140.83	£169
Ply lining - Kangoo E-Tech electric LWB	149.17	£179
Ply lining Kangoo E-Tech electric Crew LWB	140.83	£169
Rear window protection grilles	125	£160
Rear body coloured parking sensors	245.83	£295
Front body coloured parking sensors ⁽¹⁾	258.33	£310
Rubber mats	41.67	£50
Textile mats	37.50	£45
E-TECH ELECTRIC		
Charging cable 10A, domestic use (3 pin)	395.83	£475

* All prices shown are MRRP including fitment & VAT and are valid on orders until 30th September 2021. Prices shown are only valid for vehicles which will have the accessories fitted at the manufacturers import centre. Some accessories require the vehicle to be registered before fitment. Your local dealer will be able to offer further advice and supply a dealer fitted price for vehicles already in dealer stock. Accessories are fitted post production and may have an impact on real world fuel (actual) consumption and CO₂ figures. (1) Not compatible with factory fit rear parking sensors.

Further information

Vehicle	Classed As	Delivery to Dealer and Number Plates*	Vehicle Excise Duty	First Registration Fee	Total
Kangoo Van E-Tech / Kangoo Maxi E-Tech	LCV	£636	£0	£55	£691

Information correct at time of publication * Inc VAT †WLTP figures shown are for comparability purposes; only compare figures with vehicles tested to the same technical procedures. Actual real world driving results may vary depending on factors such as weather conditions, driving styles, vehicle load or any accessories fitted after registration. WLTP is a new test used for fuel consumption and CO2 figures. Please visit reault.co.uk/configure for WLTP figures for any selected options.

Renault PRO+, the specialist brand



You're the expert in your field and at Renault PRO+ we're here to guide you through ours. We're passionate about delivering products and services to move your business forward. So when you choose to partner with Renault PRO+ you can expect:

Specialist network

Renault PRO+ Centres have a dedicated commercial vehicle specialist. So whatever you're seeking advice on, there's always someone to help.

Business Commitment

Come rain or shine, we have a set of commitments in place to help maximise uptime and minimise downtime.

The future today - 100% electric

Renault PRO+ has been building, selling and maintaining electric vans since 2011. So when you're looking to make the switch, you know who to speak to.

A tailored approach

Your vehicles are as unique as your business. That's why we have a programme of conversions to deliver exactly the product you want. From 'off the shelf' conversions to a more bespoke approach. We'll guide you through.

Renault services

3 Years Warranty

Your vehicle is covered by a warranty package for up to 3 years from date of first registration (unlimited mileage during the first 24 months, followed by a further 1 year limited to a total mileage of 100,000). Your Renault Dealer is able to repair or replace without charge, parts that are found to have a material or assembly defect that is recognised by Renault. The paintwork warranty runs for 3 years and the anti-corrosion warranty for 12 years.

For Warranty Terms and Conditions please visit www.renault.co.uk/warranty.

3 Years Renault Assistance

Should you need it, we'll provide emergency roadside repairs or tow you to the nearest Renault Dealer. This service is available 24 hours a day and is provided for 36 months from the date of first registration unlimited mileage for first 24 months, then limited to a total of 100,000 miles or 3 years, whichever comes first. Assistance is provided within the UK & Northern Ireland only at roadside, home and includes national recovery and onward travel. Assistance applies to mechanical or electrical defects which are covered by warranty.

For Renault Assistance Terms and Conditions please visit www.renault.co.uk/assistance.

LCV Service Plans & Extended Warranties

Renault's LCV Service Plans are the ultimate package to provide care free servicing for your new Renault LCV.

It really is the hassle free way to take care of your Renault and benefits from;

- Inflation Proof Servicing - You know exactly what you'll pay and there are no hidden costs
- Peace of Mind - No matter where life takes you, we'll be there in over 5000 workshops across Europe
- Renault Expertise & Quality - Our highly trained technicians know your Renault inside out

The Renault LCV Service Plan contains Renault services in-line with the manufacturer's service schedule, plus comes with a complimentary vehicle safety check to ensure your Renault is in the best condition possible.

Renault LCV Extended Warranty enhancements also available. Refer to the Price Guide for more details.

For servicing plan terms and conditions visit www.renault.co.uk/serviceplan *Finance provided by Renault Finance, P.O. Box 149, Watford, WD17 1FJ. Guarantees and indemnities may be required. You must be at least 18 and a UK resident (excludes Isle of Man and Channel Islands) to apply. Subject to status, terms and conditions apply. †Calls to 0330 numbers are free if used as part of your inclusive mobile minutes and are charged at local rates from landlines. Renault UK Limited (company number 82932), registered at The Rivers Office Park, Denham Way, Maple Cross, Rickmansworth, Hertfordshire, WD3 9YS.

Service Intervals

Kangoo E-Tech electric Service: Year 1 / 12,000 miles, Year 2 / 24,000 miles and then every 2 years / 24,000 miles thereafter

Renault Network Services

No-one is better placed than Renault to maintain, fit and repair your Renault, fast. The Renault Minute (maintenance and repair with no appointment necessary) and Renault Rapide Bodycare (bumper scuffs, dings and dents, windscreen, stone chips and interior repairs...) services deliver the highest level of repair and maintenance and offer a full year's guarantee on Original Renault Parts. And don't forget to have a look at our wide range of additional equipment and accessories!

Renault iCare

Renault iCare is an innovative Service, Maintenance & Repair product that supplies Business customers with a fully supported, managed hassle free service and maintenance package.

Renault iCare is a "Pay-As-You-Go" product that insures your vehicle is maintained by Renault technical experts when work is required.

iCare provides the following benefits:

Full Service, Maintenance & Repair cover in the Renault Dealer Network

- Tyres can be included within the contract at an additional fixed cost
- Ancillary equipment can also be included (at an additional fixed monthly cost)
- Excludes: Damage/Neglect/Abuse/Glass & Bulbs

A fixed, pre agreed pence per mile rate

No excess mileage charges at the end of the contract

No pooled mileage administration

Minimalise downtime

For more information and to obtain a quote based on your requirements, please speak to your local Renault Business dealer or visit www.renault.co.uk/icare

Customer Relations

Renault knows the value of communicating with its customers and we have established effective ways to keep in touch with you. If, after speaking to your local Renault dealership, you are not completely satisfied, please contact the Renault UK Customer Relations Team on 0344 3350000† (Mon-Fri 8.00am to 6.00pm, Closed on Bank Holidays. Live Chat Mon-Fri 8.00am to 9.00pm). You can also visit our website www.renault.co.uk or write to us at: Renault UK Ltd, The Rivers Office Park, Denham Way, Maple Cross, Rickmansworth, Hertfordshire, WD3 9YS.

Finance options*

There are a wide variety of ways in which the purchase of a new vehicle can be financed. Renault Finance offers all of them, so whether you're a fleet buyer or private buyer, Renault Finance is ideally placed to tell you which plan or combination of plans best suits your needs and circumstances.



Continue the Renault Kangoo E-Tech experience
at www.renault.co.uk/vans

Although every effort has been made to ensure that the information contained within this brochure is as accurate and up to date as possible, Renault U.K. reserves the right to modify its models without notice, including their characteristics, specifications, equipment and accessories. Brochures inevitably become out of date or inaccurate in some respects, in that such characteristics, specifications equipment, or accessories may be changed after the publication date given below and can differ from the descriptions given or the photos displayed. It is therefore necessary to check with your Renault Dealer before purchasing any product that the characteristics, specifications, equipment or accessories of the vehicle on order are as advertised. The colours that appear in this document may differ slightly from the actual paint and upholstery colours.

Renault recommends 

 Prodigious

Photo credits: © Renault Marketing 3D-Commerce, A. Bernier, R. Richter, S. Agnetti, O. Banet, D. Meunier – 7701 380 808 – December 2021